

JVC

SERVICE MANUAL

COMPACT VHS CAMCORDER

GR-FXM37EK

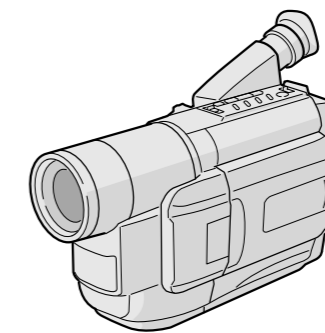

Compact VHS



Regarding service information other than these sections, refer to the GR-FXM37EG service manual (No. 86589). Also, be sure to note important safety precautions provided in the service manual.

SPECIFICATIONS

Camcorder		AC Adapter AP-V10EG	
General		Power requirement	: AC 110 V to 240 V~, 50 Hz/60 Hz
Format	: VHS PAL standard	Output	: DC 11 V ---, 1 A
Power source	: DC 11 V --- (Using AC Adapter) DC 6 V --- (Using battery pack)	Dimensions (W x H x D)	: 59 mm x 31 mm x 84 mm
Power consumption		Weight	: Approx. 140 g (not including Power Cord)
Viewfinder on	: 4.0 W	Optional Accessories	
LCD monitor on	: 4.5 W	• Battery Packs BN-V11U, BN-V12U, BN-V400U	
Signal system	: PAL-type	• Compact VHS (VHS) Cassettes EC-60/45/30	
Video recording system		• Active Carrying Bag CB-V7U	
Luminance	: FM recording	• Cassette Adapter C-P7U	
Colour	: Converted sub-carrier direct recording Conforms to VHS standard		
Cassette	: S-VHS / VHS cassette		
Tape speed			
SP	: 23.39 mm/sec.		
LP	: 11.70 mm/sec.		
Recording time (max.)			
SP	: 60 minutes		
LP	: 120 minutes (with EC-60 cassette)		
Operating temperature	: 0°C to 40°C		
Operating humidity	: 35% to 80%		
Storage temperature	: -20°C to 50°C		
Weight	: Approx. 900 g		
Dimensions (W x H x D)	: 200 mm x 112 mm x 118 mm (with the LCD monitor closed and with the viewfinder full tilted downward)		
Pickup	: 1/4" format CCD		
Lens	: F1.6, f = 3.9 mm to 62.4 mm, 16:1 power zoom lens with auto iris and macro control, filter diameter 40.5 mm		
Viewfinder	: Electronic viewfinder with 0.5" black/white CRT		
White balance adjustment	: Auto/Manual adjustment		
LCD monitor	: 2.5" diagonally measured, LCD panel/TFT active matrix system		
Speaker	: Monaural		
Connectors			
ILIP/EDIT	: ø3.5 mm, 4-pole, mini-head jack (compatible with RC-5325 plug)		
Video	: 1 V (p-p), 75 Ω unbalanced, analogue output (via Video output connector)		
Audio	: 300 mV (rms), 1 kΩ analogue output (via Audio output connector)		

Specifications shown are for SP mode unless otherwise indicated. E & O.E. Design and specifications subject to change without notice.

JVC

VICTOR COMPANY OF JAPAN, LIMITED
VIDEO DIVISION

S40894

 Printed in Japan

This service manual is printed on 100% recycled paper.
COPYRIGHT © 2001 VICTOR COMPANY OF JAPAN, LTD.

No. 86632
May 2001

TABLE OF CONTENTS

DIFFERENT TABLE 1 to 2

4. CHARTS AND DIAGRAMS

4.1 BOARD INTERCONNECTIONS 4-1

4.2 CPU SCHEMATIC DIAGRAM 4-3

4.3 VTR ASP SCHEMATIC DIAGRAM 4-5

4.4 DSP SCHEMATIC DIAGRAM 4-7

4.5 IRIS & AF/ZOOM SCHEMATIC DIAGRAM 4-9

4.6 REGULATOR SCHEMATIC DIAGRAM 4-11

4.7 LCD CTL SCHEMATIC DIAGRAM 4-13

4.8 SPEAKER AND MONITOR SCHEMATIC DIAGRAMS 4-15

4.9 MAIN CIRCUIT BOARD 4-17

4.10 MONITOR CIRCUIT BOARD 4-23

5. PARTS LIST

5.1 PACKING AND ACCESSORY ASSEMBLY <M1> 5-1

5.2 FINAL ASSEMBLY <M2> 5-3

5.3 ELECTRICAL PARTS LIST

 MAIN BOARD ASSEMBLY <01> 5-6

The following table indicate different parts number between models GR-FXM37EG and GR-FXM37EK.

PACKING AND ACCESSORY ASSEMBLY <M1> Note: As for IB (INSTRUCTION), refer to sec.5.

REF. NO.	MODEL		GR-FXM37EG	GR-FXM37EK
	ITEM			
2	CUSHION		* LY32065-001A	LY32065-001B
4	POLY BAG		QPA02003506	YQM30061-3
6	LENS CAP		* LY41538-002B	LY41538-003A
7	WARRANTY CARD/GUARANTY CARD		BT-54013-1	BT-54008-2
△ 9	POWER CORD		QMPL120-190-JR	QMPP110-190-JR
△ 10	AC ADAPTER		* LY20688-001A	LY20688-001B
△ 13	Q.CARD(JUK)		—	LYT0194-001B

Note: Mark — is not used. Mark * reference model was also changed.

FINAL ASSEMBLY <M2>

REF. NO.	ITEM	MODEL	GR-FXM37EG	GR-FXM37EK
101F	SCREW		* QYSLSF2060D	QYSLSF2050Z
102	COVER(JACK)		* LY31945-001B	LY31945-001C
105	CASS.COVER(M)ASSY		* LY20694-002A	LY20694-002B
111	REAR UNIT		* LY20615-004A	LY20615-004B
115	SCREW		* QYSLSF2060D,X5	QYSLSF2060D,X4
121	SCREW,X3		* QYSLSF2060D	QYSLSF2050Z
136	SCREW/SPECIAL SCREW		* QYSLSF2060D	LY42981-001A
138	SCREW		* -	QYSLSF2060D

MONITOR ASSEMBLY <M5>

REF. NO.	ITEM	MODEL	GR-FXM37EG	GR-FXM37EK
△ 501	M.COVER ASSY		* LY20679-005A	LY20679-005C
515	HOLDER(2.5PWB)		* LY20672-001A	LY20672-001B
520	LCD MODULE		* QLD0154-001	QLD0176-001

MAIN BOARD ASSEMBLY <01>

REF. NO.	ITEM	MODEL	GR-FXM37EG	GR-FXM37EK
PW	MAIN BOARD ASSY		* YB10310EH-01	YB10310EH-04

MONITOR BOARD ASSEMBLY <07>

REF. NO.	ITEM	MODEL	GR-FXM37EG	GR-FXM37EK
PW	MONITOR BOARD ASSY		* YB20900B-01	YB20900B-02
Q7501,Q7502	POW TRANSISTOR/TRANSISTOR		* 2SC3647/ST/-X	2SD1644/QR/-W
Q7504	TRANSISTOR		* 2SC4617/QR/-X	DTC144EE
R7506,R7507	MG RESISTOR		* NRSA63J-473X	-
C7503	MPPS CAPACITOR		* NFV41HJ-273X	-
C7511	CAPACITOR		* -	NCB21EK-273X

Note: Mark - is not used. Mark * reference model was also changed.